

FLOW RATE INDICATOR

WITH VERY LARGE DIGITS



D-Series advantages

- Unique, robust IP66, IP67 (NEMA4X) panel mount front enclosure made of die cast aluminum, allowing even **big jets** of water and **total immersion**.
- Programming can be done by your own crew with the exact same, plain and sensible menu-driven structure like the F-Series, saving cost and irritation. **Know one, know them all!**

Features

- Displays flow rate and measuring units.
- Very large 26mm (1") digits.
- Piegraph indication: ten segments.
- Selectable on-screen engineering units; volumetric or mass.
- Ability to process all types of flow meter signals.
- Auto backup of all settings.
- Ambient temperature -40°C up to +80°C (-40°F up to 176°F).
- LED backlight option.
- Input loop powered, battery powered or 8 - 30V DC, 24V AC and 115 - 230V AC.
- Sensor supply 1.2 / 3 / 8.2 / 12 / 24V DC.

Signal input

Flow

- Reed-switch.
- NAMUR.
- NPN/PNP pulse.
- Sine wave (coil).
- Active pulse signals.
- (0)4 - 20mA.
- 0 - 10V DC.

Applications

- The D-Series is a DIN-sized display and the **better alternative** for your existing, not waterproof, front panel mount indicators in extreme weather outdoor applications or e.g. in food industries where working environments are often cleaned with powerful water jets.
- The Do10 fits in flow measurement applications where a local flow rate indication is required without re-transmission or totalizer functionality. Alternative advanced models: Do12, Do13, Do14, Do16 or the F-Series flow rate indicators.

General information

Introduction

The Do10 is a local, panel mount indicator to display the actual flow rate. The measuring and time unit to be displayed are simply selected through an alpha-numerical configuration menu. No adhesive labels have to be put on the outside of the enclosure: a weather proof and user friendly solution! The configuration of K-factors or Span and number of decimals is done through software functions, without any sensitive dip-switches or trimmers.

Display

The display has very large 26mm (1") digits which can be set to show the flow rate and the measuring and time units. The display is a transfective type, which means that a high contrast reading is guaranteed, even in full sunlight. The Do10 has a smart display update function incorporated. Related to the lower temperatures, the update frequency of the LCD is tuned automatically to achieve a readable display even at -40°C / -40°F.

Backlight

For those applications where readability during day and night is an issue, a bi-color backlight is available. The background color can be set to green or amber and the intensity can be adjusted in the configuration menu.

Configuration

All configuration settings are accessed via a simple operator menu which can be password protected. Each setting is clearly indicated with an alphanumerical description, which avoids confusing abbreviations and baffling codes. Once familiar with one D-series product, you will be able to program **all models in all series** without a manual. All settings are safely stored in EEPROM memory in the event of sudden power failure.

Signal input

The Do10 accepts most pulse and analog input signals for volumetric flow or mass flow measurement. The input signal type can be selected by the user in the configuration menu without having to adjust any sensitive mechanical dip-switches, jumpers or trimmers. The analog input is available with linear and square root calculation and even as 4 - 20mA input loop powered.

Power requirements

The basic power supply for the Do10 is 8 - 30V DC. Several other power supplies are possible: With the 24V AC/DC and 115 - 230V AC power supplies, an 8.2 / 12 / 24V DC sensor supply is offered. For analog sensors, a 4 - 20mA input loop powered version is available. Finally we offer a long life lithium battery with a life expectancy that will last up to five years.

Enclosure

The Do10 is supplied in a unique, robust IP66, IP67 (NEMA4X) class panel mount front enclosure made of die cast aluminum, based on a popular DIN sized enclosure of 144 x 72mm. The front enclosure withstands powerful water jets and even total immersion. The maximum thickness of the panel is 6mm (1/4"). The D-Series is the better alternative for your existing, not waterproof, front panel mounted indicators.

Overview application Do10

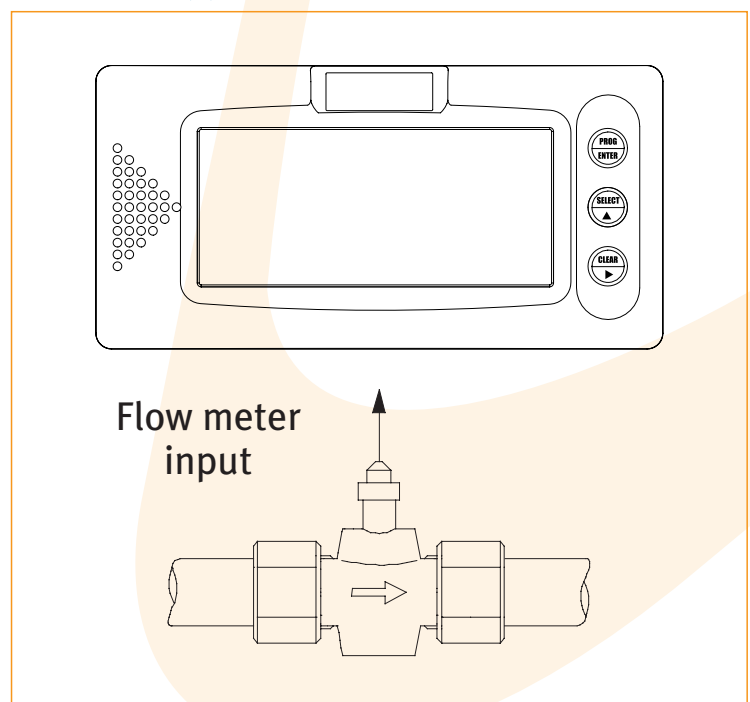

Dimensions enclosure

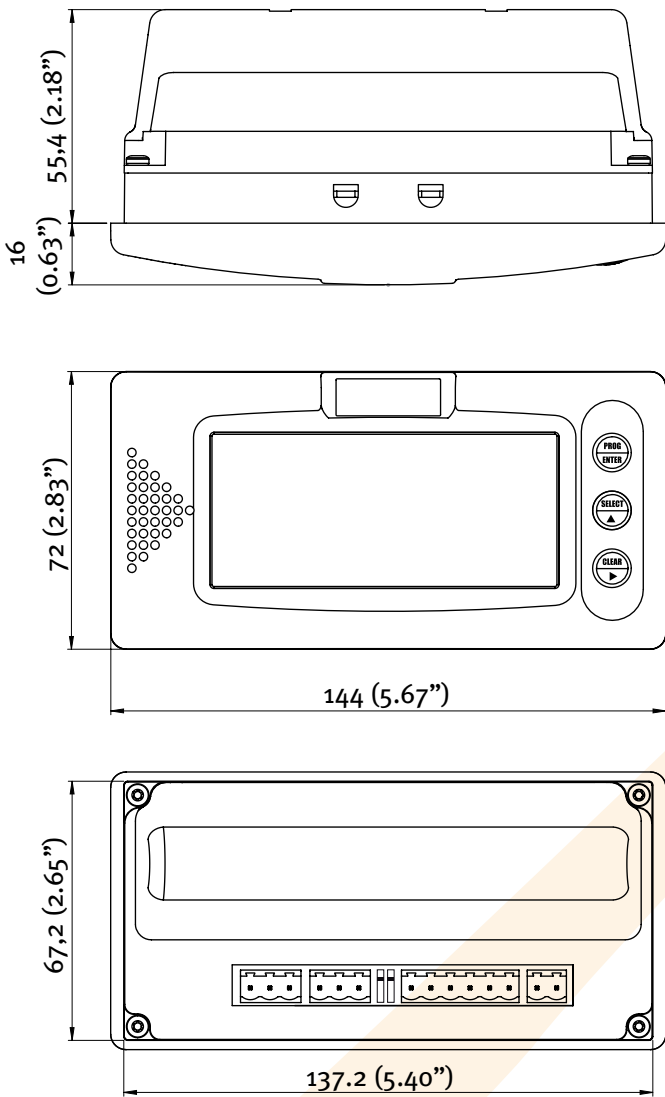

Dimensions according DIN 43700 / IEC 61554

Dimensions panel cut-out

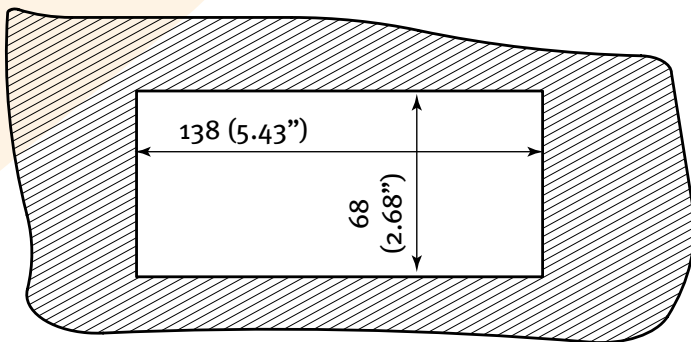

Maximum panel thickness: 6mm (1/4")

Terminal connections Do10

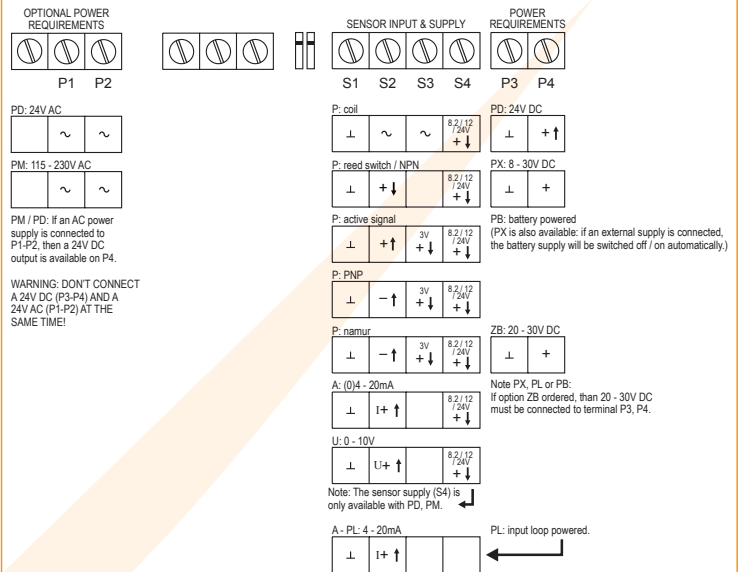

Display example - 90 x 40mm (3.5" x 1.6")



Wiring diagram Do10-P-PB-(PX)-(ZB)

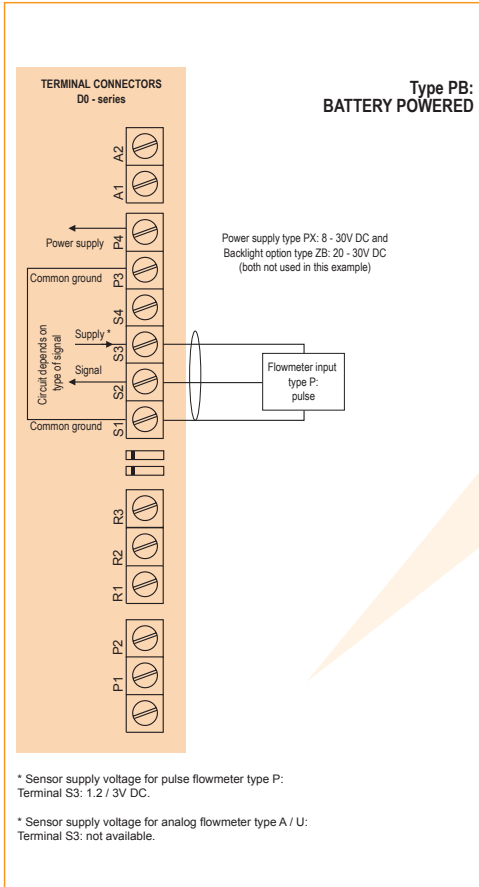

Wiring diagram Do10-A-PX-(ZB)

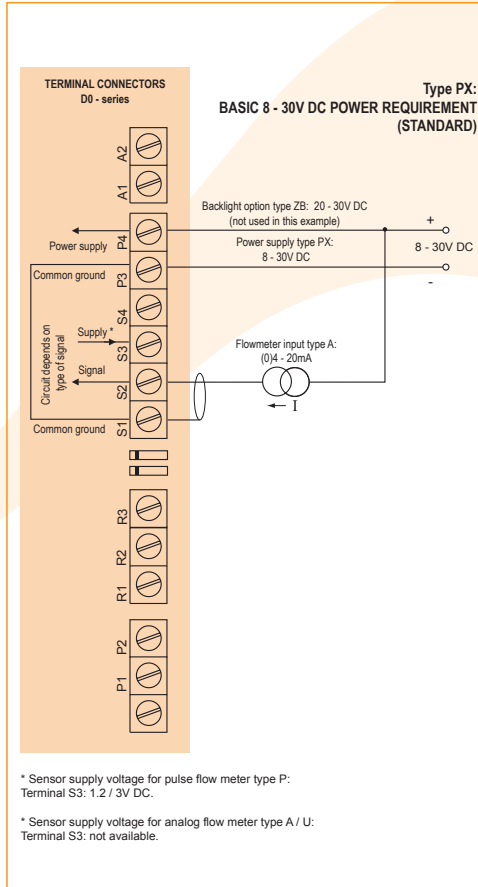

Wiring diagram Do10-P-PD-ZB

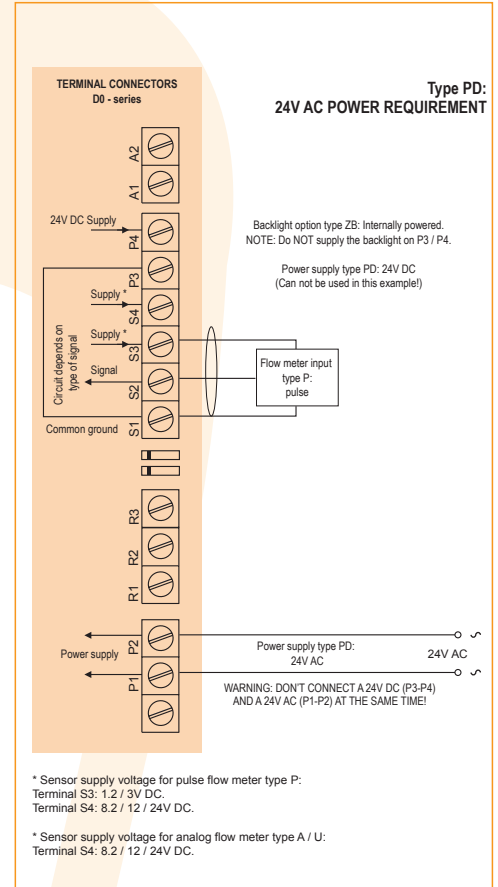

Wiring diagram Do10-A-PL-ZB

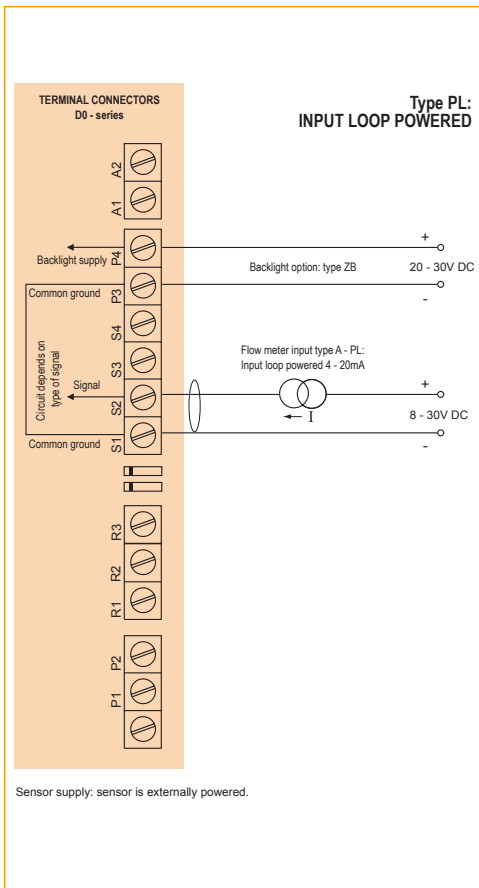

Wiring diagram Do10-P-PD-ZB

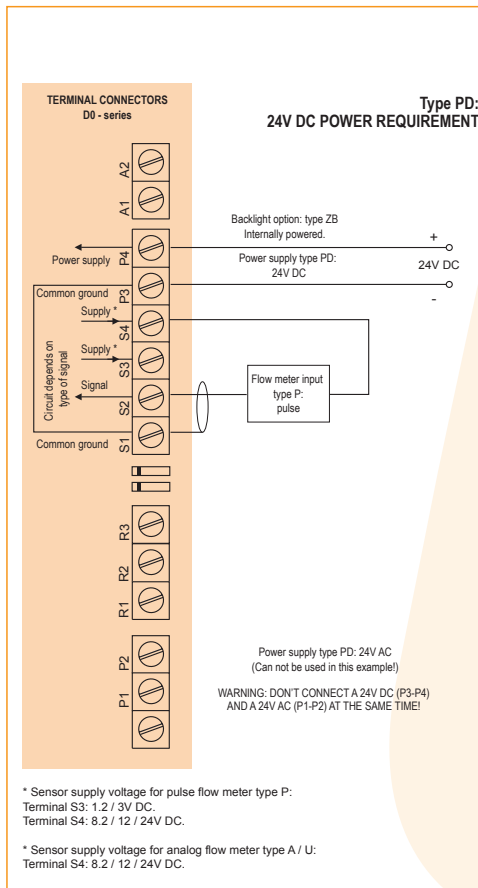

Wiring diagram Do10-P-PM-ZB

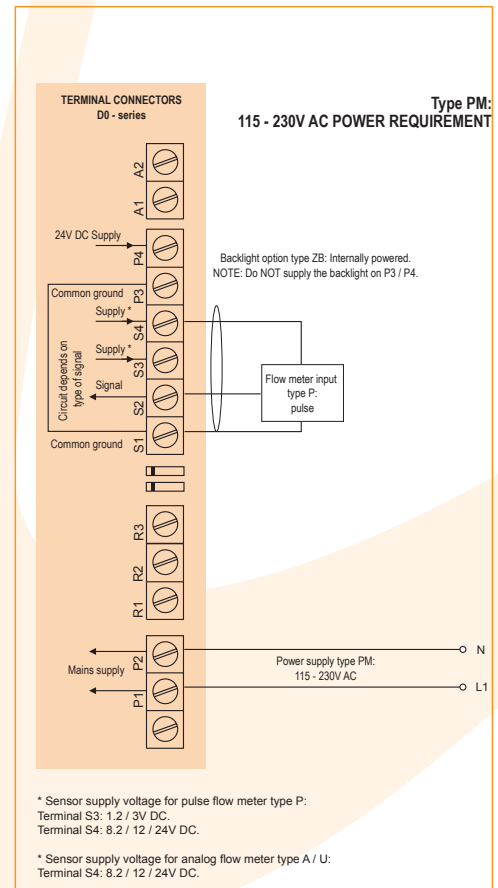

Technical specification

General

Display	
Type	High intensity reflective numeric and alphanumeric LCD, UV-resistant.
Dimensions	90 x 40mm (3.5" x 1.6").
Digits	5½ very large 26mm (1") digits. Various symbols and measuring units.
Piegraph	Ten segments - related to the input signal.
Refresh rate	User definable: fast, 1sec, 3sec, 15sec, 30sec, off.
Option ZB	Transflective LCD with bi-color LED-backlight; green / amber. Intensity and color can be adjusted in the configuration menu. Good readings in full sunlight and darkness.

Ambient temperature

Safe areas	-40°C to +80°C (-40°F to +176°F).
------------	-----------------------------------

Power requirements

Type PB	Long life Lithium battery - life-time depends upon settings and configuration - up to 5 years.
Type PD	24V AC/DC ± 10%. Power consumption max. 1 Watt.
Type PL	Input loop powered from sensor signal 4 - 20mA (requires type A).
Type PM	115 - 230V AC ± 10%. Power consumption max. 1 Watt.
Type PX	8 - 30V DC. Power consumption max. 0.3 Watt.
Type ZB	20 - 30V DC. Power consumption max. 1 Watt. With type PD / PM: internally powered.

Sensor excitation

Type PB/PX	3V DC for pulse signals and 1.2V DC for coil pick-up.
Note	This is not a real sensor supply. Only suitable for sensors with a very low power consumption like coils (sine wave) and reed-switches.
Type PD / PM	for pulse signals: 1.2 / 3 / 8.2 / 12 / 24V DC For analog signals: 8.2 / 12 / 24V DC 8.2V DC, Iout max. 35mA @ 20°C. 12V DC, Iout max. 50mA @ 20°C. 24V DC, Iout max. 75mA @ 20°C. (this voltage can vary depending on the input supply voltage)

Terminal connections

Type	Removable plug-in terminal strip. Wire max. 1.5mm² and 2.5mm².
------	---

Data protection

Type	EEPROM backup of all settings. Data retention at least 10 years.
Password	Configuration settings can be password protected.

Directives & Standards

EMC	Directive 2004/108/EC, FCC 47 CFR part 15.
Low voltage	Directive 2006/95/EC.
IP & NEMA	EN 60529 & NEMA 250.

Enclosure

General	
Window	Polycarbonate window.
Sealing	Silicone.
Control keys	Three industrial micro-switch keys. UV-resistant silicone keypad.

Panel mount enclosure

Dimensions	144 x 72 x 71.4mm (5.67" x 2.83" x 2.81") - W x H x D according DIN 43700 / IEC 61554.
Panel cut-out	138 x 68mm (5.43" x 2.68") L x H.
Material	Die-cast aluminum front panel + GRP back enclosure
Protection	IP66, IP67 (NEMA 4X) at the front-side.
Weight	325 gr.
Panel thickness	Max. 6mm (¼").

Signal input

Flow meter sensor	
Type P	Coil / sine wave (HI: 20mVpp or LO: 80mVpp - sensitivity selectable), NPN/PNP, open collector, reed-switch, Namur, active pulse signals 8.2 - 12 - 24V DC.
Frequency	Minimum 0Hz - maximum 7kHz for total and flow rate. Maximum frequency depends on signal type and internal low-pass filter. E.g. reed switch with low-pass filter: max. frequency 120Hz.
K-Factor	0.00001 - 199,999 with variable decimal position.
Low-pass filter	Available for all pulse signals.
Option ZF	coil sensitivity 10mVpp.
Option ZG	coil sensitivity 5mVpp.
Type A	(0)4 - 20mA. Analog input signal can be scaled to any desired range within 0 - 20mA.
Type U	0 - 10V DC. Analog input signal can be scaled to any desired range within 0 - 10V DC.
Accuracy	Resolution: 16 bit. Error < 0.01mA / ± 0.05% FS. Low level cut-off programmable.
Span	0.00001 - 199,999 with variable decimal position.
Update time	Four times per second.
Voltage drop	Type A: max. 1V DC @ 20mA.
Voltage drop	Type A - PL (loop powered): max. 2.6V DC @ 20mA.
Load impedance	Type U: 3kΩ.
Relationship	Linear and square root calculation.
Note	For signal type A and U: external power to sensor is required; e.g. type PD / PM.

Operational

Operator functions	
Displayed functions	<ul style="list-style-type: none"> Flow rate. Measuring and time units.

Flow rate

Digits	5½ digits.
Units	mL, L, m³, Gallons, kg, Ton, lb, bl, cf, RND, ft³, scf, Nm³, NL, igital - no units.
Decimals	0 - 1 - 2 or 5.
Time units	/sec - /min - /hr - /day.

Ordering information

Standard configuration: D010-P-HB-PX-ZX.

ordering information:	D010	-	-HB	-P	-Z
Flow meter input signal					
A	(0)4 - 20mA input.				
P	Pulse input: coil, npn, pnp, namur, reed-switch.				
U	0 - 10V DC input.				
Panel mount front enclosure - IP66, IP67 (NEMA4X)					
HB	Aluminum DIN 43700 / IEC 61554 front panel.				
Power requirements					
PB	Lithium battery powered.				
PD	24V AC / DC + sensor supply.				
PL	Input loop powered from sensor signal 4 - 20mA - requires type A.				
PM	115 - 230V AC + sensor supply.				
PX	Basic power supply 8 - 30V DC (no real sensor supply).				
Other options					
ZB	Backlight.				
ZF	Coil input 10mVpp - requires type P.				
ZG	Coil input 5mVpp - requires type P.				
ZX	No options.				

The bold marked text contains the standard configuration.

Specifications are subject to change without notice.



Fluidwell bv
P.O. Box 6
5460 AA - Veghel - The Netherlands
Telephone: +31 (0)413 343 786
Telefax: +31 (0)413 363 443
email: displays@fluidwell.com
Internet: www.fluidwell.com

