

Technical Datasheet



ZHM...ST Series

Gear Flow Meters

for lubricating, non lubricating and abrasive fluids

Application

Thanks to their robust design the gear flow meters of the series "ZHM ST" are suited for applications with lubrication and non-lubrication liquids as well as for filled viscous and abrasive media. The parts of products of this series are manufactured exclusively of high-grade stainless steel, so these products are also suited for applications with corrosive materials.

Various design sizes of the flowmeters of the series ZHM KL allow a wide range of applications in such areas as consumption measuring, monitoring, mixing and dosing. Optimal measurement accuracy as well as good dynamic characteristics are guaranteed thanks to very high-quality bearings made of sintered carbides (hard metal). Short reaction times and exact dosing and flow measuring can be therefore performed in different areas of applications.

Principle and Design

Gear flowmeters are volumetric counters that have internal design similar to gear pumps. There are two gear wheels inside the flowmeter body; they have mutual engagement with a minimum backlash.

Between the teeth and walls of the flowmeter body closed chambers arise into which medium forced-flows and it puts thereby the gear wheels in motion.

The gear wheels move freely and do not brake the medium flow. Their number of revolutions is proportional to the flow rate and is sensed using contactless sensors through the body wall.

Applications

- Waterborne paints, clear coatings, 2-component paints, highly-filled metal paints and sofffeel paints
- Coating wax, glues, PVC, epoxy resin, highly-filled and abrasive fluids
- Polyol- and isocyanate
- Oil, fat (also food and cosmetics)
- Filling processes
- Dosing systems
- Lubrication-monitoring
- Light acids and alkalis

Features

- High output frequency
- Short response
- Resistant to pressure up to 630 bar
- Puls duplication- and quadruplication
- Stainless materials
- Corrosion-resistant design
- Applicable also in ESTA facilities

Technical Data

Type	Measuring range, l/min			K-Factor, pulses/l ¹⁾	max. Pressure, bar	Frequency, in Hz ¹⁾			Weight, kg
		to					to		
ZHM 01*	0.005	to	1	41,000	630	3.4	to	680	1.3
ZHM 01/1 ¹⁾ *	0.005	to	2	26,500	630	2.2	to	880	1.3
ZHM 01/2 ¹⁾ *	0.02	to	3	14,000	630	4.6	to	700	1.6
ZHM 02/1 ¹⁾ *	0.05	to	2	8,200	630	6.8	to	273	2.1
ZHM 02 ¹⁾ *	0.1	to	7	4,200	630	7	to	490	2.2
ZHM 03*	0.5	to	25	1,740	630	14	to	730	2.9
ZHM 04*	0.5	to	70	475	630	4	to	560	8.5
ZHM 05*	5	to	150	134	400	11	to	340	23
ZHM 06/1*	5	to	250	106	400	8.8	to	450	27
ZHM 06*	20	to	500	53	400	18	to	450	35
ZHM 07*	50	to	1,000	24	400	20	to	400	66.5

1) Average values with single-pickup TYP VTE*/P. Use twin-pickup for higher resolution.

* Detailed type code on request

General

Linearity	± 0.5% of actual flow (≥ 30 mm ² /s; up to 0.1% with linearization electronics)
Repeatability	± 0.1%
Materials	Housing: as per DIN 1.4305 (SS303), Gears: as per DIN 1.4122 Bearing: Carbide Sealing: FKM, PTFE, NBR, Isolast®, Kalrez®
Medium temperature	-20 to +180°C (higher temperatures on request)
Dimensions	See drawing (page 4 to 5)

Pickup Selection

Criteria	Type	VTE *	WT */ WI*	VIE *	IF */ VIEG	VTC *	VTB *	TD *	VHE*	FOP *
Drilling type ¹⁾		E	E	E	E	E	E	D	E	E/F
Medium temperature	≤ +70°C							✓		
	≤ +120°C					✓	✓		✓	✓
	≤ +150°C	✓	✓	✓						
	≤ +350°C				✓					
EX-Approval		✓	✓	✓	✓	✓	✓	✓		✓
Frequency output		✓	✓	✓	✓	✓		✓	✓	✓
Dual frequency output								✓		
Analogue output 4 - 20 mA			✓			✓				
Forward / backward recognition								✓		
Local display						✓	✓			
Linearization			✓			✓				
Supply 12 - 24 V		✓	✓	✓	✓	✓		✓	✓	
Supply battery							✓			✓
Interface			✓			✓				

1) Thread types: E: single pickup / D: dual pickup / F: FOP-pickup

* Ordering code (please see separate datasheet)

Dimensional Drawings (mm) - ZHM 01 to 05

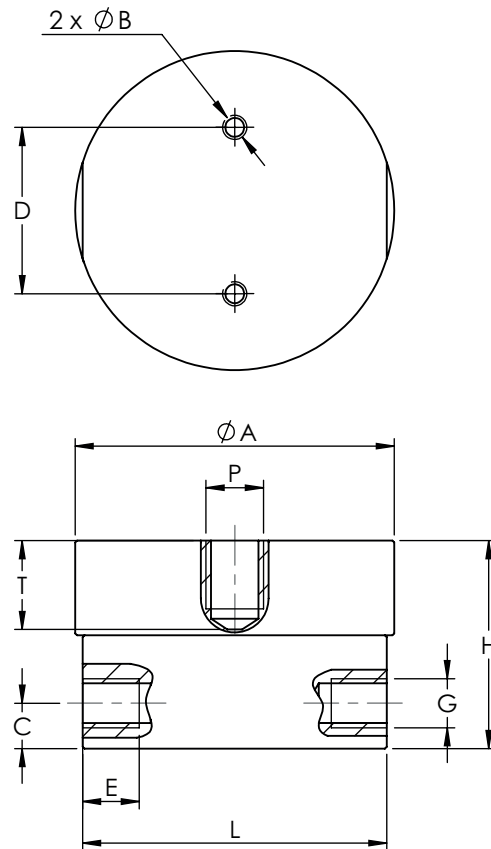

ZHM Type	Ø A	B	C	D	E	G	H	L	P ¹⁾	T ²⁾
ZHM 01	76	M6 ↓ 10	10.5	44	14	M12x1.5	41	72	D/E/F	19
ZHM 01/1	76	M6 ↓ 10	10.5	44	14	M12x1.5	47	72	D/E/F	18
ZHM 01/2	76	M6 ↓ 10	12	44	14	M12x1.5	50	72	D/E/F	18
ZHM 02	84.4	M6 ↓ 10	12	44	14	M12x1.5	55	80.5	D/E/F	23.5
ZHM 02/1	84.4	M6 ↓ 10	12	44	14	M12x1.5	51	80.5	D/E/F	23.5
ZHM 03	84.4	M6 ↓ 10	12	44	14	M12x1.5	67	80.5	D/E/F	23.5
ZHM 04	125	M6 ↓ 10	17	60	18	M20x1.5	96	121	D/E/F	30.5
ZHM 05	175.5	M8 ↓ 15	22.5	100	18	M33x2	133	170	D/E/F	43.5

1) See "Pickup Selection" table (P. 3)

2) Please notice: total height is calculated by adding up the height (H) and the height of the pickup (separate data sheet) and subtract the bore hole depth (T)

Dimensional Drawings (mm) - ZHA 06/1 to 07

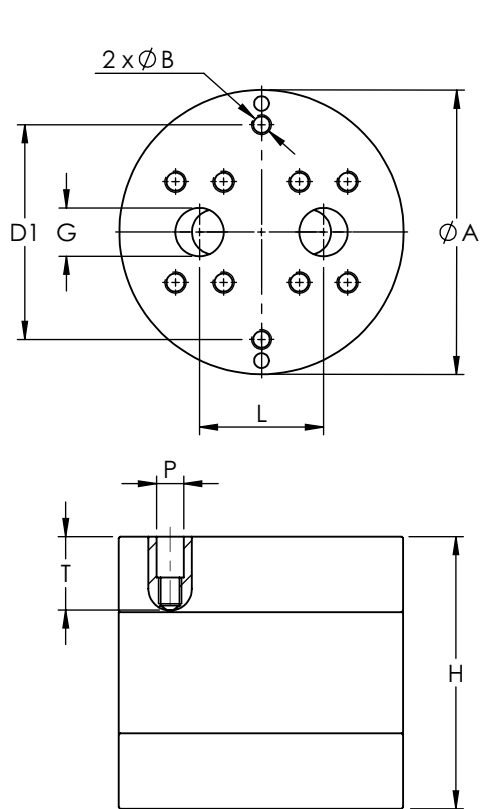

ZHM06-06/1

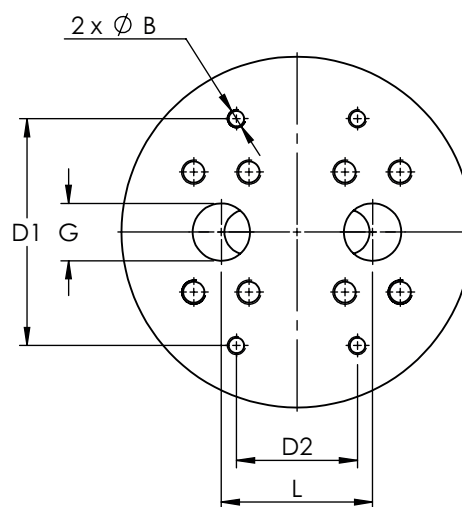

ZHM07

ZHM Type	Ø A	B	D1	D2	G	H	L	P ¹⁾	T ²⁾
ZHM 06/1	188,5	M12 ∇ 25	142	-	SAE 1 1/4"	138	82	D/E	48,5
ZHM 06	188,5	M12 ∇ 25	142	-	SAE 1 1/4"	180	82	D/E	48
ZHM 07	233	M12 ∇ 25	150	80	SAE 1 1/2"	220	100	D/E	63

1) See "Pickup Selection" table (P. 3)

2) Please notice: total height is calculated by adding up the height (H) and the height of the pickup (separate data sheet) and subtract the bore hole depth (T)

KEM Headquarter

Liebigstraße 5
85757 Karlsfeld
Deutschland

T. +49 8131 59391-0
F. +49 8131 92604

info@kem-kueppers.com

KEM Service & Repairs

Wetzeller Straße 22
93444 Bad Kötzting
Deutschland

T. +49 9941 9423-0
F. +49 9941 9423-23

info@kem-kueppers.com



*More distributors & partners can be found at:
www.kem-kueppers.com*